

# Stainless steel shop desk chest of drawers

Dimensions in mm

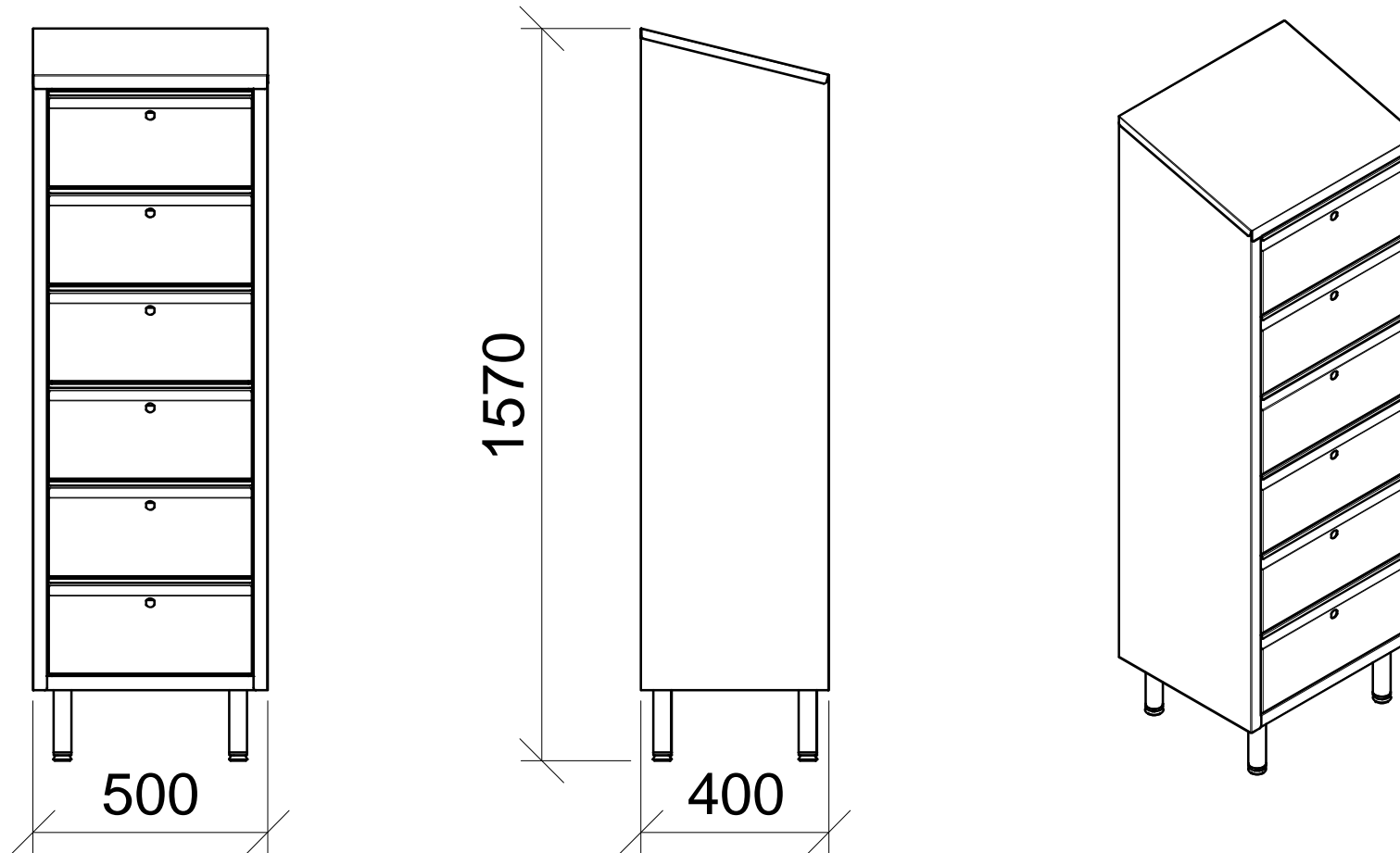

## CHARACTERISTICS: 21 gauge

- 0,8 mm thick stainless steel.
- 2J finish (Scotch-Brite®).
- Inclined writing top with pen stop.
- 6 drawers with cylindrical key lock.
- Adjustable screw on feet.
- Optional with 4 swivel casters.

Code: X4350

**FACILITAS**

Via Lazio 7 A/B/C - 41050 Montale Rangone (MO)  
Web: [www.facilitas.it](http://www.facilitas.it) @: [facilitas@facilitas.it](mailto:facilitas@facilitas.it)  
Tel: +39 (0)59-530570 Fax: +39 (0)59-4909000